

Tools Required:

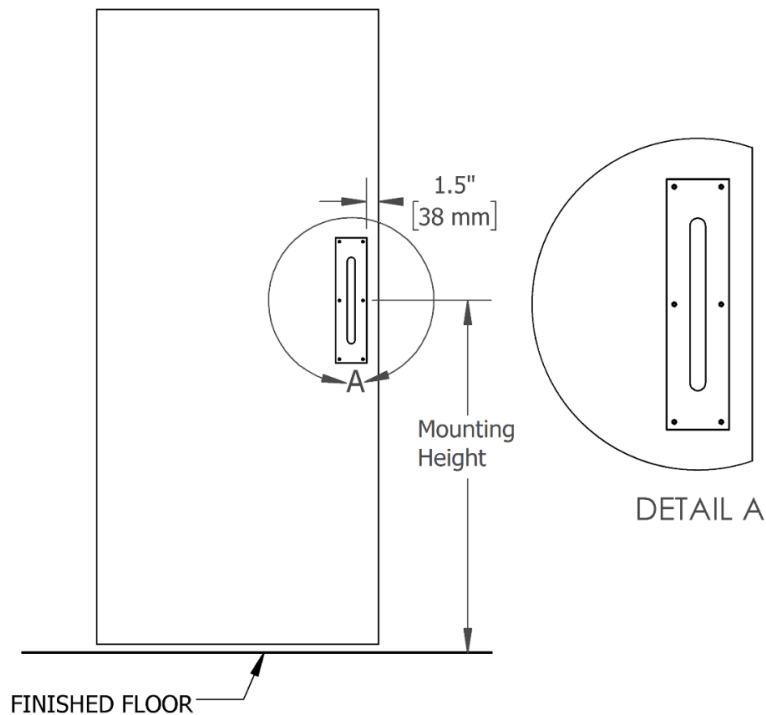
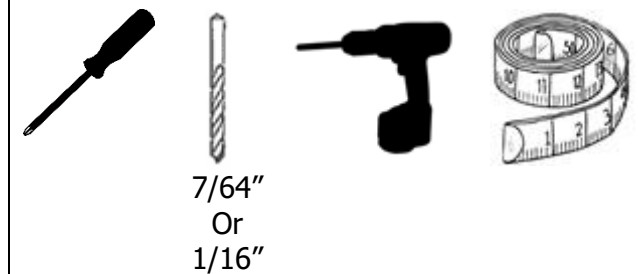

1. Mount the pull to the front of the pull plate
2. Determine the mounting height of the pull plate on the door. (According to the International Building Code 2018 and 2010 ADA standards, door pulls shall be installed 34 inches (864 mm) minimum and 48 inches (1219 mm) maximum above the finished floor).
3. Place the pull plate on the door so that the edge of plate is 1.5" [38 mm] from the edge of the door
4. Once the pull plate is on the desired position, mark the door using the pull plate holes as a template
5. Using a 7/64" drill bit (Hollow Metal Doors) or 1/16" drill bit (Solid Core Wood Doors), drill pilot holes through the marked spots created on step 4. (Be sure not to drill all the way through).
6. Install the pull plate using the #6 x 5/8" Thread Forming Screw.