



# SLAL-250-BP-4DR

Aluminum Sliding Door Hardware — By-Pass

## PRODUCT CUT SHEET

PROJECT:
SUBMITTED BY:
DATE:
NOTES:

### Top Mount Track System



- Commercial Grade for 1 $\frac{3}{8}$ " to 1 $\frac{3}{4}$ " Doors
- Max Weight Load: 250 lbs.
- ANSI/BHMA A156.14 Grade 1 Certified to 100,000 Cycles Including Soft Close Feature
- Hangers with Heavy-Duty Ball Bearing Wheels
- 5-Year Warranty
- Track Comes in 48", 60", 72", 96" and 144" Lengths

#### Complete Kits Include:

- (1) Track –Mill Finish
- (4) Universal Hardware Packs, Each Consist Of:
  - (2) Ball Bearing Heavy-Duty Hangers
  - (2) Snap-In Door Brackets
  - (2) In-Track Stops
  - (1) Angle Stop
  - (1) Bumper Stop
  - (1) Door Guide
  - Heavy-Duty Floor Guides

Note: For Door Sizing Refer to Installation Instruction.

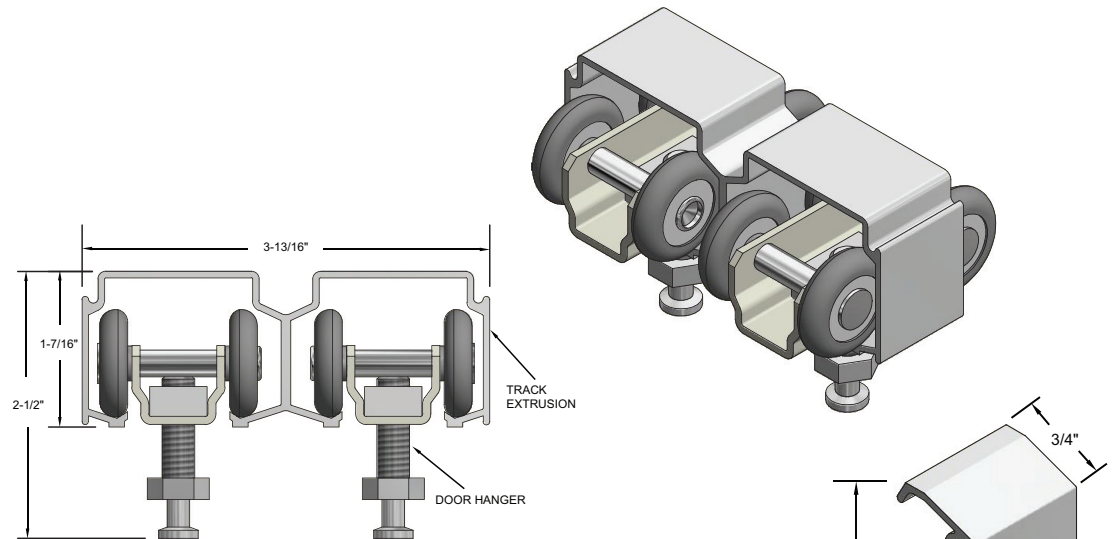

#### OPTIONS:

- Soft Close / Open – Specify “SCBY”  
For Both Directions Order (2) Sets SCBY
- Bottom Channel Guide SL-BCG
- Snap-On Fascia (SL-SQ20) –  
Clear Anodized

Note: For Door Sizing Refer to Installation Instruction.

NGP-SLI-SLAL-250-BP-4DR-PCS-0422-C