

STEP 3:INSTALL FIRE RATED BOLT

- 1.Insert bolt and use the provided screws to secure bolt.
- 2.3/16" x 1/2" flat head machine screws and 3/16" x 5/8" flat head, self-tapping machine screws for metal door use.
- 3.5/32" x 3/4" flat head wood screws for wood door use.

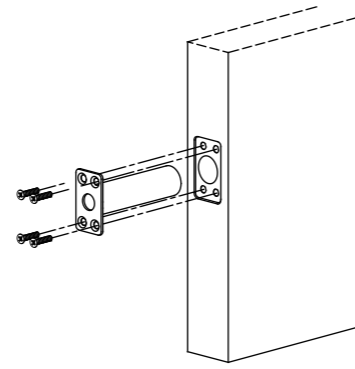

STEP 4:INSTALL STRIKE HOLE PLUG

- 1.Insert hole plug into the 1" hole in strike door leaf.
- 2.Self adjusting tabs on the hole plug will lock in place to secure the plug.

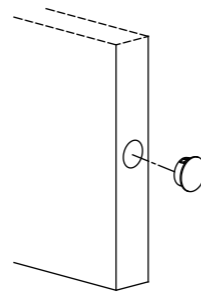

STEP 5:REVIEW INSTALLATION

- 1.Close both doors and verify fire rated bolt and strike hole are lined up.
- 2.Be sure the door gap directly in front of the fire rated bolt is not covered with a door edge guard or any other similar type of device.

REMARKS:

- 1.Refer to F1000V devices Installation Instructions for further details.
- 2.Before installing head cover,insert head cover plug into bottom side of head cover first.

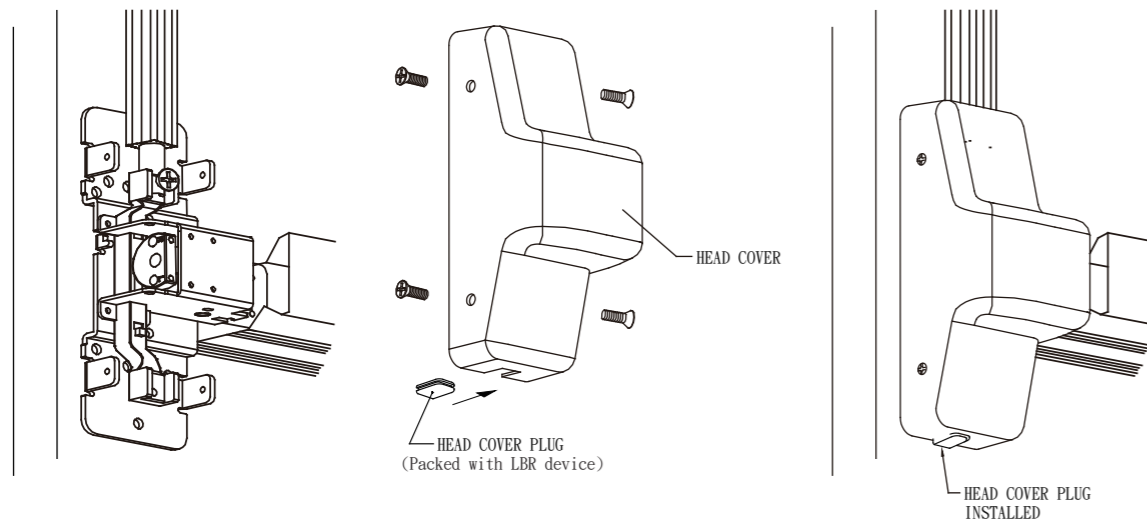

FIRE RATED BOLT

F1000V LBR

INSTALLATION INSTRUCTIONS

A IDENTIFICATION OF PARTS

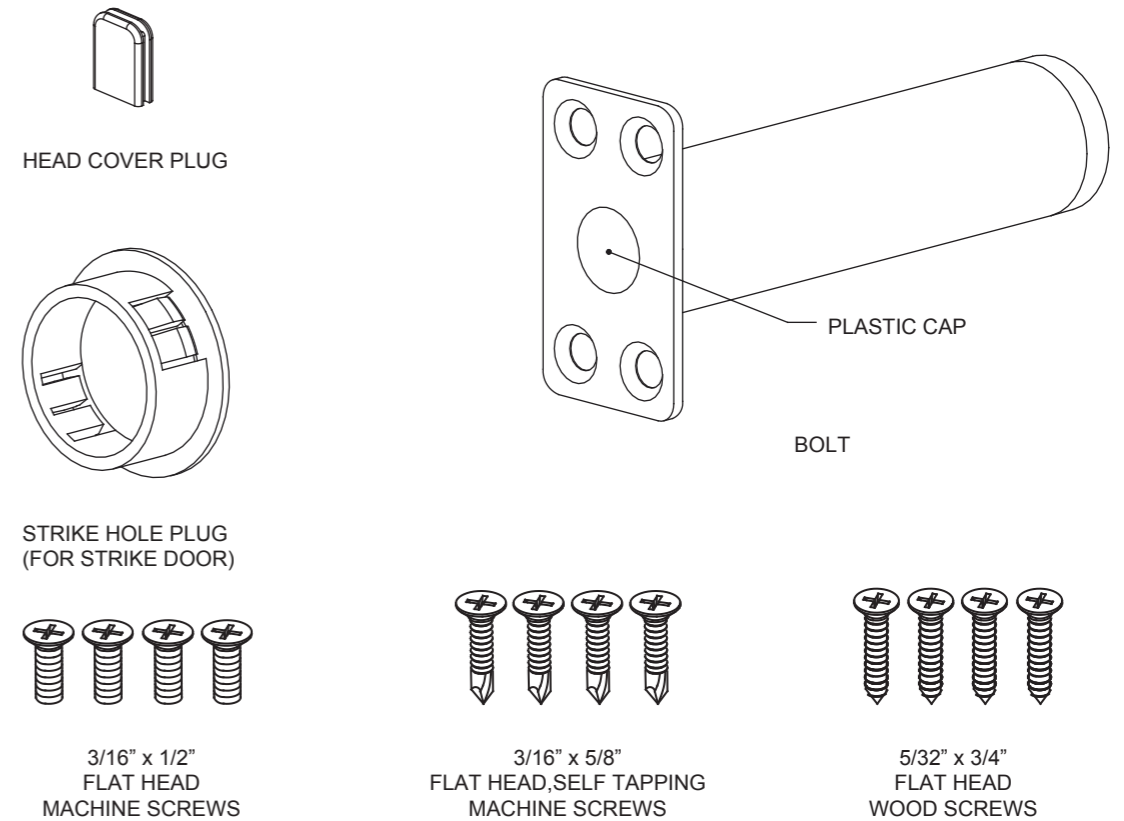

B TOOLS REQUIRED

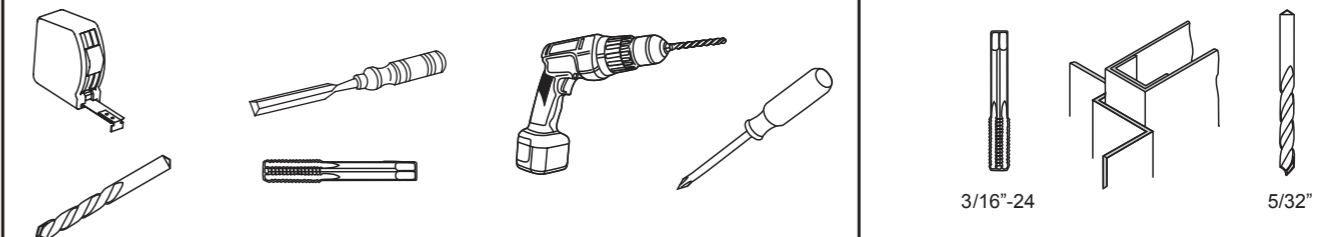

C IMPORTANT NOTES - READ BEFORE INSTALLING

- 1.The bolt will keep the doors in alignment during a fire when the pin extends from the bolt case into the strike hole in the opposite door.For the pin to extend into the strike hole,the plastic cap visible on the face of the bolt and the strike hole plug must melt.Therefore,do not cover the door gap directly in front of the bolt with a door edge guard or any other similar type of device.
- 2.A double door application consists of two LBR devices and one fire rated bolt.The fire rated bolt should be installed in the inactive door to maintain fire listing.
- 3.The fire rated bolt is only for use with F1000V LBR devices. F1000V LBR devices come with a standard top strike, which must be utilized to maintain fire listing.
- 4.Refer to the F1000V devices Installation Instructions for further details on the F1000V LBR devices.
- 5.The following parts and screws of F1000V device are **not necessary** when installing F1000V LBR device:



ROD CONNECTOR (1 PCS)

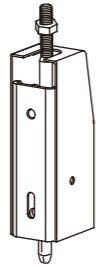

BOTTOM LATCH UNIT



BOTTOM ROD

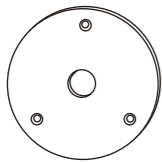

FLOOR STRIKE

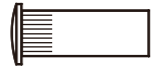

THRU BOLTS (2 PCS)

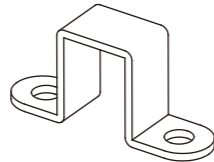

ROD GUIDE (1 PCS)



ROD GUIDE INSERT (1 PCS)



1/4" x 1" (3 PCS) ANCHOR



1/4"-20P x 3/4" (2 PCS) ROUND HEAD MACHINE SCREWS (SS material)



1/4"x 1" (2 PCS) ROUND HEAD WOOD SCREWS (SS material)



8# x 5/8" (2 PCS) ROUND HEAD SELF TAPPING MACHINE SCREWS (SS material)



5/32" x 3/4" (3 PCS) FLAT HEAD WOOD SCREWS (SS material)



1/4"-20P x 3/4" (2 PCS) ROUND HEAD MACHINE SCREWS



14#x1 1/2" (2 PCS) FLAT HEAD SELF TAPPING MACHINE SCREWS



1/4"x 1 1/4" (2 PCS) ROUND HEAD WOOD SCREWS

D INSTALLATION PROCEDURES:

STEP 1:PREPARE FIRE RATED BOLT DOOR LEAF

- 1.Mark horizontal centerline 6"[152 mm] from the bottom of door.
- 2.Mark vertical centerline at center of door thickness.
- 3.Drill a 7/8"[22 mm] diameter by 3-7/16"[87 mm] deep hole in the auxiliary fire bolt door leaf.
- 4.Insert fire rated bolt in hole,keeping it parallel to face of door. Mark outline of bolt face plate and remove bolt.
- 5.Chisel 7/64"[2.8mm] deep or until bolt face plate is flush with door edge.

STEP 2:PREPARE STRIKE HOLE PLUG DOOR LEAF

- 1.Transfer horizontal centerline from bolt door leaf.
- 2.Mark vertical centerline at center of door thickness.
- 3.Drill a 1"[25mm] diameter by 1-3/4"[44mm] deep hole in the strike plug door leaf.

